



Accessibility
on a whole new level

MCI D45 CRT LE

Welcome to the future of commuter rapid transit

Newly reimagined, the MCI® D45 CRT LE commuter coach warmly welcomes all passengers, creating an innovative low-entry vestibule with a ramp and adjoining seating area designed with mobility devices in mind. Beyond game-changing accessibility features to speed entry and exit, the all-new model offers modern good looks and the amenities that commuters have come to expect from MCI, including comfortable forward-facing seats, power outlets, parcel racks and Wi-Fi options, plus the sturdy reliability that has long made the MCI commuter coach the leading choice for commuter express. And, with an electric version available starting in 2020, the D45 CRT LE will be the greenest choice for communities.

D45: Represents the next-generation D-Series commuter coach

CRT: Designed for transit systems with Commuter Rapid Transit routes

LE: With a groundbreaking, patent-pending Low-Entry design





COMMUTER

EXPRESS

MCI
D45 CRT LE

MCI

333



A coach for your
entire community



Everyone aboard: The new D45 CRT LE

Technological advances and styling improvements, along with passengers' and operators' requirements have inspired a complete redesign of MCI's commuter coach, the industry's number-one choice for commuter service.

It's the first new D-Series commuter coach in 25 years. Long recognized for passenger comfort and proven reliability, the MCI commuter coach has the best mean distance between failure rate (MDBF) compared with our competitors.

It also represents MCI's vision for the future of public transit. The new D45 CRT LE was designed with changing passenger demographics in mind. As some riders give up their cars or avoid buying automobiles altogether, the need for accessible mass transit has never been greater. The MCI D45 CRT LE commuter coach provides an efficient, comfortable response to this demographic evolution with innovative features:

- Second door
- Boarding times comparable to low floor transit
- Low-entry vestibule with five seats
- Modern design
- Seats 54 passengers
- ADA and Buy America compliant
- Seats 52 with two mobility devices

The breakthrough low-entry vestibule design offers unprecedented ease of entry and exit, and a new standard of comfort. The new model provides everything your system will need to serve your passengers, especially those with specific mobility needs.



Low-entry mid-door

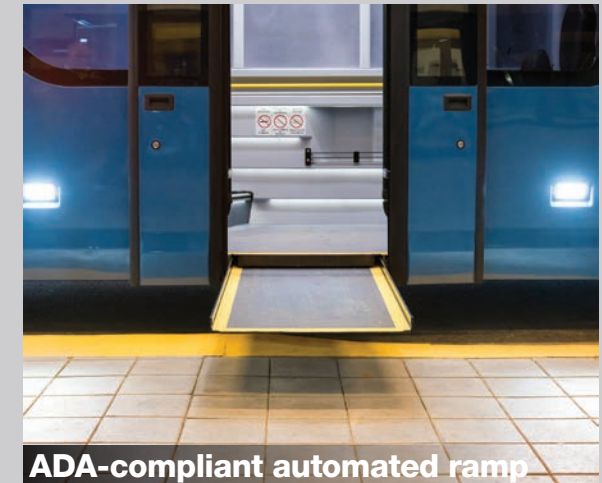

ADA-compliant automated ramp



Easy entry and exit

Our workhorse reputation



Stainless steel tubing

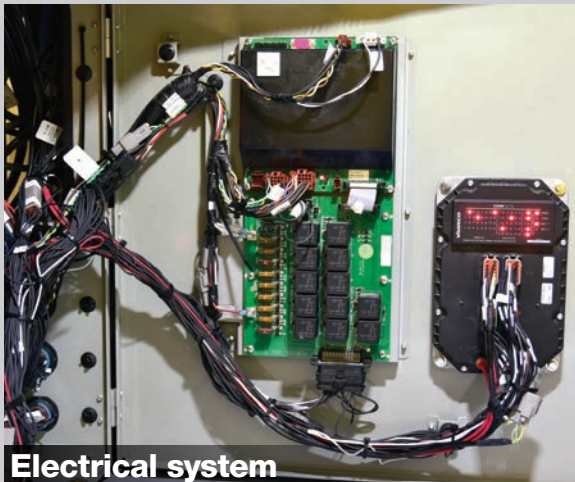

Electrical system



Quality manufacturing

Reliable design

It's not enough for an MCI commuter coach to be technologically and aesthetically superior. It has to be dependable day in and day out. One look at our semi-monocoque construction and you'll understand why our family of D-Series coaches, including the commuter coach, are known as workhorses in the public transit industry.

These are just a few of the ways that MCI is Reliability Driven™:

- 1. Our sturdy, full stainless steel frame** resists the elements and provides dependable long-term structural integrity. Our newest model features increased stainless componentry, and overall reduced parts count for simplicity.
- 2. Single-piece, thick-walled stainless steel tubing** in critical areas such as our window posts add strength, durability and excellent fit and finish.
- 3. Electrical systems are simplified**, using less wiring and fewer modules. And for durability and environmental protection, we tightly seal all compartments and connectors.

Reliable manufacturing

To say that our people are Reliability Driven™ means that everyone at MCI does his or her part to make our products the safest and most durable on the road. Today, we lead the industry in manufacturing, innovative design and service. As part of NFI Group, and a sibling of New Flyer, the leader in low-floor transit buses, we have a combined 200 years of industry experience with 5,600 employees that support over 44,000 transit buses and 28,000 motor coaches now on the road in the United States and Canada. We are dedicated to building upon our legacy to bring you the coach of the future.



COMMUTER

MCI

MCI
DASH CITY LE



Low-Entry Vestibule: First-of-its-kind design for increased accessibility

When we asked what we could do to make the MCI commuter coach even more efficient for public transit systems, our operators were ready with the answer.

The more efficiently passengers can enter and exit a coach, the lower the dwell time, facilitating passenger satisfaction and ridership growth.

We began by looking at how to ease boarding for all passengers, including those with mobility devices. We ended up with a way to improve the pace, comfort and convenience of commuter transit overall.

Our design participants

MCI's design engineers worked closely with Designworks, A BMW Group Company, and engaged volunteer members from several advocacy organizations including the National Council on Independent Living (NCIL), Society of Manitobans with Disabilities (SMD) and The American Association of People with Disabilities (AAPD) to develop the D45 CRT LE.

Following rigorous analysis and testing, our low-entry, mid-door vestibule concept emerged the winner from among 32 designs.

Designworks
A BMW Group Company



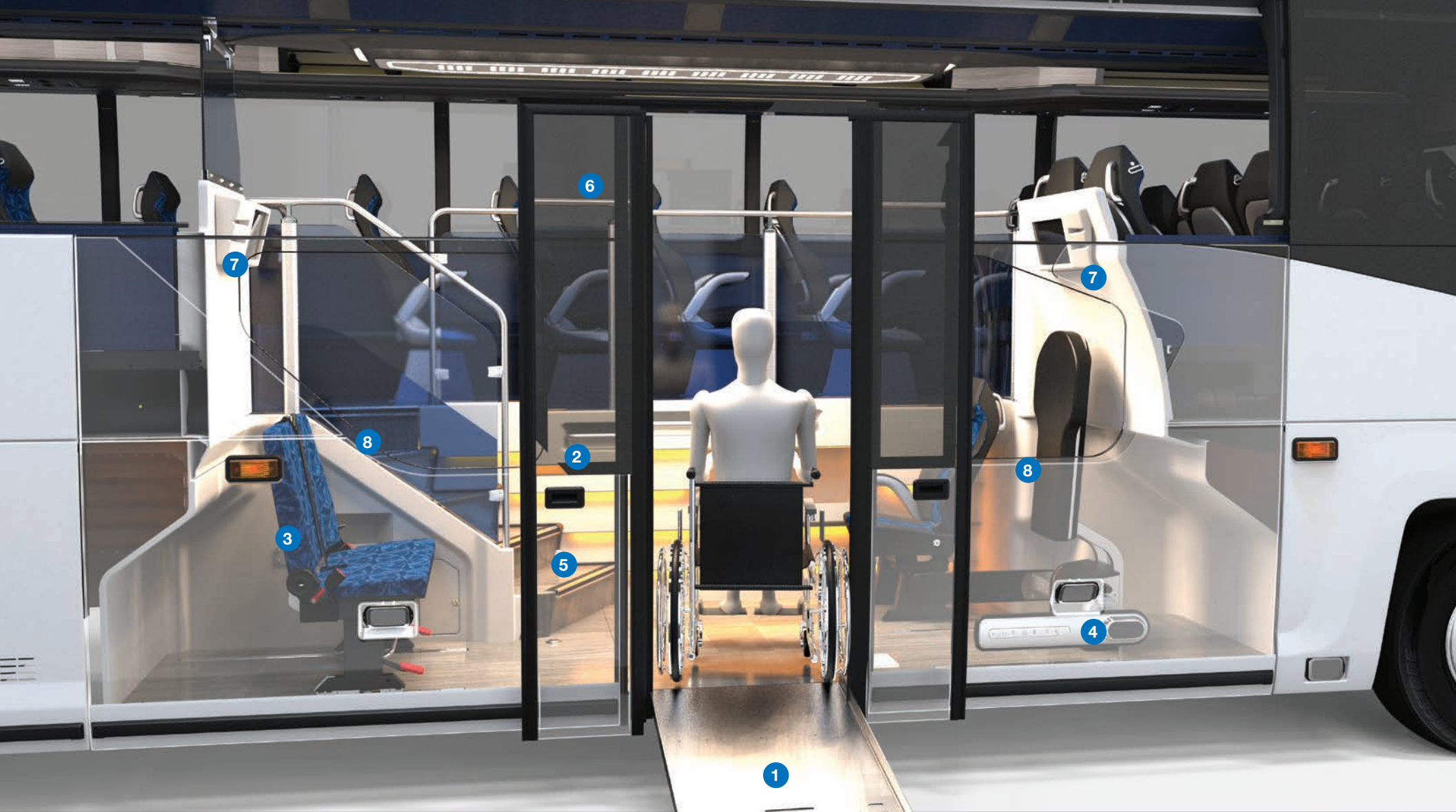
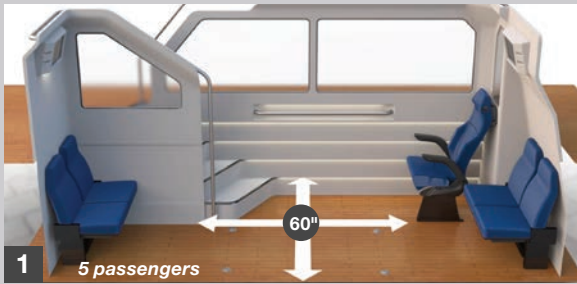

Illustration of the mid-door entry and vestibule

1. Second door with automated ramp
2. Lower-level vestibule area with capacity for up to 5 seats or two mobility devices
3. Seats flip up to make space for mobility devices
4. Optional Quantum automated wheelchair securement system shown
5. Second step well
6. 54 seat capacity with 49 elevated seats
7. REI monitors in the vestibule area
8. Expansive windows for those using mobility devices

Breakthrough design



Our new ADA-compliant automated ramp with a slope of 6:1 extends a full six feet and is 30 inches wide with a higher weight capacity than traditional lifts. This allows the D45 CRT LE to accommodate a wider variety of mobility aids, including next-generation motorized wheelchairs and other devices.

Once inside, the spacious vestibule has seating configurations that include up to two riders using mobility devices. Possible configurations are illustrated at left.

- 1 Five seats in the lower vestibule
- 2 Single forward-facing position
- 3 Rearward with Quantum
- 4 Rearward and forward position
- 5 Two forward positions

MCI offers the manual Q-Strait wheelchair securement system as standard, and the automated Quantum as an option for the rear facing position on the right of the vestibule.

“We believe that this product offers many advantages over standard high-floor motor coaches, primarily used in Commuter Express and scheduled route service. We are grateful that an equipment manufacturer sought user input in advance and during the development.”

— Kelly Buckland, Executive Director,
National Council of Independent Living

“AAPD has reviewed the research and concept for Motor Coach Industries (MCI) new Low Entry (Vestibule) commuter motor coach. We commend MCI for taking a customer focused approach in developing their new design.”

— Helena Berger, President and CEO,
The American Association of People
with Disabilities

Passenger benefits

- Easy accessibility, rapid entry and exit via two doors
- Dignified boarding and a comfortable riding experience for passengers with mobility disabilities
- New ramp provides loading times comparable to low-floor transit buses with flip ramps

Operator benefits

- Faster loading and unloading decreases dwell time
- Improved wheelchair securement



Form follows function



1. A range of interior options maximize comfort and durability
2. Convenient handles on the backs of seats enhance safety and mobility
3. Continuous one-piece handrails on parcel rack are ergonomically designed for improved safety and aesthetics



4. Standard LED indirect ceiling lighting
5. Standard LED tube lights
6. Optional LED window lighting
7. Best-in-class parcel rack space
8. Adjustable passenger modules with LED integrated seatbelt signs
9. Integrated center aisle ramp improves ease of entry and exit
10. FMVSS 210 compliant seats with three-point seatbelts available with or without integrated headrests



11. Optional rear window





5

4

6

11

10

9

Unique features, reliable benefits

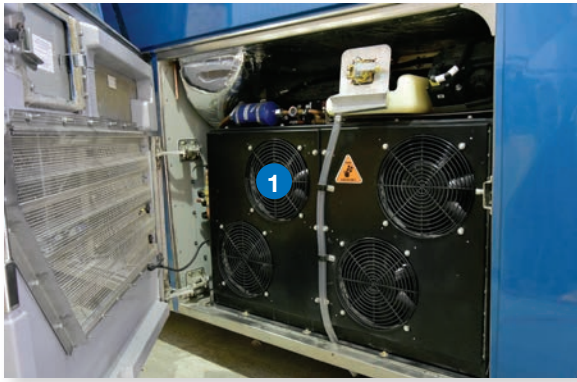

1. The brushless motors on the HVAC evaporator and condenser motors significantly improve reliability and reduce maintenance with an expected 10-year life

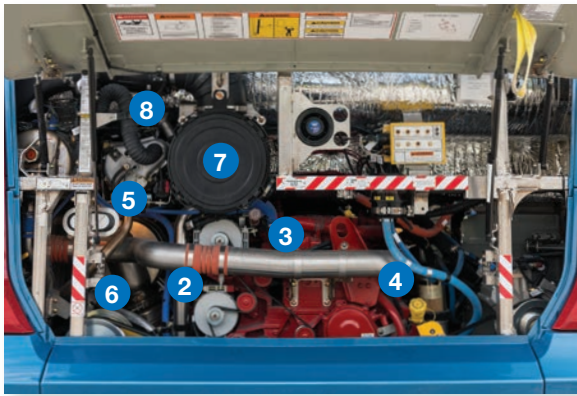

2. The rugged brushless alternators reduce maintenance
3. Quieter operations and stronger fuel economy (tested at 9.66 MPG at 65 MPH through independent study)
4. The redesigned A/C compressor belt roller has increased reliability and reduced noise and vibration
5. Updated standard Amerex fire-suppression system provides a more reliable response
6. Improved fan drive life
7. New engine air filter
8. New standard engine air intake pre-filter/water separator



Large rear transom windows

The optional LED rear docking light improves visibility

Digital wheel-end shutdown programming notifies the driver and initiates coach shutdown in the event of an over-temperature condition

Optional 360° camera system

Standard passive rear steering with Sachs shocks enhances MCI wide-ride performance with tight turning

MDSS system improves operational reliability and includes standard high/low rise features

Patent-pending Low-Entry vestibule with ample room for 2 passengers with mobility devices



- 9. Optional rear window
- 10. Optional rear route sign
- 11. Rear rise, high rise or low rise suspension settings
- 12. Baggage compartment doors with keyed or optional electric locks
- 13. Mid-mounted air intake with standard pre-cleaner

Optional drip rail lighting

Laminated safety glass with dual-latch emergency release mechanism

Provisions for front, side and rear destination signs

Optional Bendix Wingman Advanced adaptive cruise with collision mitigation radar technology provides advanced driver assistance



- 14. Robust lower structure in both front and rear, with energy-absorbing bumpers

32" clear width mid-coach door with ADA-compliant 6:1 sloped ramp rated to 1,000 lbs.

Bendix ADB 22X brakes provide automotive-level stopping feel, common rotors to reduce parts and provide greater serviceability

NEW wider front door with spiral entry

Optional LED headlights are long lasting, easier to service and brighter LED DRL/turn lights enhance visual impact and visibility



- 15. Spare-tire roller to improve ease of access and removal of the spare



Extra-mile style, inside and out

No more trade-offs

The D45 CRT LE blends eye-appealing design with the rugged, durable, heavy-duty operational qualities required by transit operators.

We started with a clean slate and developed a coach that has the best-in-class-accessibility; passenger-pleasing amenities such as overhead reading lights and airflow controls; and new, more modern styling, inside and out.

The MCI D45 CRT LE delivers a stunning silhouette with two points of entry and exit, panoramic frameless windows and a refashioned front and rear end. An optional rear window adds extra visibility and natural light to the cabin. Still, what passengers will appreciate most are the interior's ergonomic achievements. The addition of MCI's trademark spiral stairway at the front entry point and increased door width opens up the aisle and places the fare box closer to the driver's dash for better clearance. This allows passengers to get on and off more quickly. For safety and comfort, MCI includes sturdy stainless steel grab rails and illumination on step nosing.

Details that make the difference

The roofline's integrated drip rails and extra inch in overall height keep the model within New York Port Authority and Lincoln Tunnel limits but add stature to an already stunning silhouette.

The independent front suspension system and standard passive rear tag give our newest commuter coach a tight turning radius of 40 feet and 11 inches – better to more easily maneuver through congested city streets, tight parking lots and garages.

The Bendix ADB 22x braking system delivers car-like control, and optional collision mitigation technology uses a forward-mounted radar sensor to issue warnings and prompt active driver intervention to help avoid incidents.





Fare generator

High-capacity seating benefits operators, passengers alike

Transit systems committing existing low-floor equipment to commuter express may want to consider the benefits of MCI's purposefully built commuter coach. Low-floor city buses are designed for shorter distance, fixed-route trips. The D45 CRT LE, much like the current D-Series model, is built to withstand the rigors of longer-distance commuter rapid transit and highway routes, and now offers improved accessibility.

Inside, there's ample legroom with maximum capacity seating for 54 passengers—52 when two passengers are using mobility devices in place of flip-down seating. Forward-facing, reclining seats, parcel racks, overhead lighting, optional power outlets, and Wi-Fi are more of the special amenities distance passengers want—giving them the ability to work, read or rest for the entire ride.

And a comfortable coach like the MCI D45 CRT LE can't be beat for its seating options, roomy floor plan and lower price per seat advantage.

Accessibility enhancements	Current D-Series	D45 CRT LE	Typical Articulated Bus
Capacity w/ No PMB*	57+0=57	54+0=54	55+0=55
Capacity w/ 1 PMB*	51+1=52	52+1=53	51+1=52
Capacity w/ 2 PMB*	47+2=49	50+2=52	47+2=49

*Passengers with mobility devices

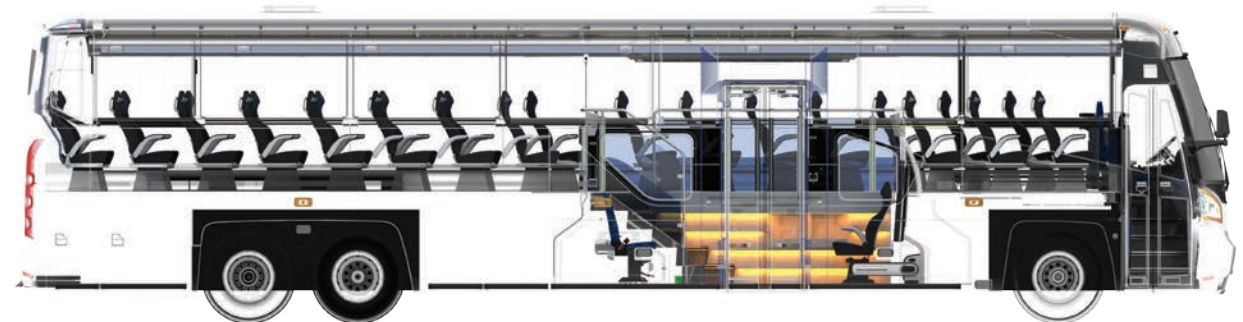



Cockpit details

1. Notched dash for farebox installation
2. **NEW!** Multifunction dash display
3. Steering wheel with integrated controls for accessing diagnostic information via the dash display
4. Driver's cupholder
5. Storage pocket
6. Tray with USB accessory power
7. 12V accessory power
8. Large driver's toll window
9. Choice of USSC or Recaro driver's seat
10. MCI curved stepwell
11. Ergonomic driver's workspace

Integrated high-definition Parker-Vansco instrument panel

New, large 12" TFT (Thin Film Transistor) instrument panel display, easy to read day and night, has these capabilities:

- Enhanced on-screen diagnostic capabilities with the ability to provide "plain English" system status messages, including DPF warnings.
- Access to on-screen menus via steering wheel controls.
- Easily convertible from imperial to metric units (programming only).
- New enhancements can be added via programming updates.

Just for the driver

MCI believes that transit drivers of its coaches should be just as comfortable as the passengers they serve. That's why MCI has updated its cockpit with a redesigned, ergonomic dash featuring easier-to-read gauges on a new integrated high-definition instrument panel that sits lower for better sight lines and puts intuitive controls within reach.

Safety and value you can count on

Safety, regulatory compliance and transit systems' need for lowest total cost of ownership (TCO) are driving innovation at MCI. While no system replaces safe driving habits, the new D45 CRT LE captures and adapts the newest safety technologies including electronic stability control (which helps secure directional stability), fire suppression systems and optional collision mitigation technology.

For the total lowest cost of operation in the industry, the MCI commuter coach is designed to meet the rigors of a 12-year operating life.

To further strengthen a public transit agency's return on investment, the D45 CRT LE is built with an all stainless steel frame for robust reliability. Buy America compliant and tested at Altoona, the new model proves worthy of the demands of public sector applications, while setting a new benchmark for an entire industry.





Accessible, comfortable and environmentally friendly



You've never seen a coach built for the highway quite like the MCI D45 CRT LE

Available in clean-diesel and CNG engine configurations, with an electric version planned for 2020 delivery, the MCI D45 CRT LE is simply a greener choice for communities.

All-electric and lightning fast

The all-electric MCI D45 CRT LE will utilize a high-torque Siemens 2130 LB FT Electric Drive System for operation at highway speeds with a planned range to meet long-distance commuter applications, currently up to 480 kWh. As for charging, the vehicle allows for high power plug-in battery EV charging to 100 percent in under three hours. Now part of the New Flyer family, MCI is able to leverage the company's expertise and experience in manufacturing electric buses.

CNG at its best

MCI delivered its first CNG-powered commuter coach in 1999. Today, there are hundreds of CNG MCI models in the fleets of agencies* nationwide, with many units still in service after 12 years/500,000 miles. Equipped with an industry-proven compressed natural gas system by Agility Fuel Systems™, the CNG commuter coach delivers significant savings as well as clean-air benefits, with most operators seeing 15 to 28 percent lower operating and maintenance costs compared to diesel equivalents.**

*CNG MCI Commuter Coaches are in service with Los Angeles Department of Transportation and NJ TRANSIT.

**Alternative Fuels and Advanced Vehicles Data Center at the Department of Energy.

MCI D45 CRT LE Specification Highlights

Legend

S = Standard
O = Optional

Base
Spec

Safety and Security

Amerex fire-suppression system and engine compartment fire detection	S
Digital Wheel End Sensing (DWES) to detect wheel end faults	S
FMVSS 210 load compliant seat track and mounting system with infinite adjustability	S
Bendix® ESP (Electronic Stability Program)	S
Bendix® Wingman Advanced System with Adaptive Cruise Control and Collision Mitigation Functionality	O
High-visibility yellow ergonomic handrails throughout the vehicle	S
Display monitors in the vestibule area	S
Integrated tire-pressure monitoring system with always-on sensors	O
Frameless single pane passenger emergency egress windows with laminated safety glass and dual-latch	S
Frameless dual pane passenger emergency egress windows with tempered / laminated safety glass and dual-latch	O
Spare tire compartment roller	S
Brigade 360 degree camera system	O
Brigade 500 GB (4 exterior cameras) or 1 TB (4 interior & 4 exterior cameras) digital recording system	O

Powertrain and Economy

2017 EPA Cummins ISX 12 liter w/ engine brake, 425hp, 1,450 lb-ft torque	S
Allison Gen V transmission with prognostics capability	S
Fuel economy optimized rear axle ratios	S
“Cummins Connected” option for enhanced engine diagnostics	O
Relocated engine air intake system including standard pre-filter / water separator and enhanced engine compartment service lighting	S
2 x 150 Amp Denso alternators for improved reliability	S
45,000 BTU ProHeat or 120,000 BTU Spheros (Webasto) auxiliary heaters	O
Linnig electromagnetic 3-speed fan clutch	S

Exterior

Semi-monocoque low-corrosion stainless steel body	S
Fiberglass composite front and rear caps, exterior skin and baggage doors	S
Dual entry / egress locations - air operated bi-part entrance and mid-coach doors	S
Ultra durable front and rear bumper systems	S
Patent-pending headlight bezel design for easier service access	S
Long-life, high-visibility LED high/low beam forward lighting	O
Drip rail overhead lighting	O
New acrylic rear tail lamp panels	S
Fog lamps with impact resistant polycarbonate lenses	O
Hub-piloted steel wheels, 22.5 x 9.0 inch	S
Alcoa aluminum wheels with Durabrite coating, 22.5 x 9.0 inch	O
Firestone® tires 315/80 R22.5, L-rated	S
Michelin® tires 315/80 R22.5, L-rated	O

MCI D45 CRT LE Specification Highlights

Legend S = Standard
O = Optional

Base
Spec

Handling, Ride and Braking

Independent Front Suspension system with labyrinthically sealed unitized wheel ends - 17,000 lb rating	S
23,000 lb drive axle and 16,500 lb tag axle with independent suspension	S
Bendix® all-wheel ADB 22X™ disc brakes	S
Tilt and telescoping steering wheel with integrated controls and ZF variable ratio steering	S
Wide-ride suspension system with Sachs shocks	S
Passive rear steering system provides amazingly tight 40' 11" turning radius	S
Extreme duty tag axle unload valves for MDSS / Bendix air system	S

Passenger Interior, Appointments and Convenience

Patent-pending vestibule area with ample room for mobility challenged passengers and their companions, offering greatly reduced dwell times and greater independence	S
MCI-exclusive mid-coach door with vestibule area and integrated ramp conforming to the latest ADA 6:1 slope guidelines	S
Best-in-class interior passenger space with comfortable seating for 54 passengers (53 passengers with 1 mobility device or 52 passengers with 2 mobility devices)	S
MCI-exclusive front spiral entrance stairway with ergonomic grab rails	S
USSC A-220 thin-back seat for improved passenger space, with separate headrest and integral 3-point seatbelts	S
Kiel 2050 or 1020 seating featuring modern styling and integral 3-point seatbelts	O
USSC GT seating with integrated headrest and FMVSS 210 compliant 3-point seatbelts	O
Quantum automatic restraint system	O
Rear window for improved passenger visibility and ambiance	O
Large rear transom windows	S
LED tube lights in ceiling	S
Enhanced LED interior lighting choices including stepwell nosing lights and window lights	O
Industry leading capacity parcel racks featuring more robust components and improved aesthetics	S
Enclosed parcel racks	O
Customizable fabric, flooring and interior trim options	S
Larger, re-configured lavatory with vandal resistant features	O

Driver's Cockpit, Instrumentation and Controls

New, multifunction dash display with greatly enhanced functionality, improved driver ergonomics, and "plain English" diagnostic messages	S
Multi-function steering wheel	S
Notched dash for easy installation of fare box	S
USSC or Recaro 3-point driver seats with seatbelt alarm	S
Enhanced pre-trip walk-around test check for easier inspections	S
Driver's toe kick area, streamlined LH console with larger cup holder and 12V plus USB charging ports.	S
Power windshield blinds without guide rods that recess into the front upper cap when not in use	S
New, unbreakable driver's defrost vents	S

MCI D45 CRT LE Specification Highlights

Legend

S = Standard
O = Optional

Base
Spec

Electronics Systems

Latest generation Parker/Vansco fully multiplexed solid-state electrical system featuring optimized military-grade components	S
110V outlets w/USB at every seat, including 4000 Watt inverter and integral battery charger	O
Improved Wi-Fi system options	O
Saucon asset tracking system with geo-fencing and OBR (on-board recording) capability	O
Generic 12V power supply provided for Wi-Fi installation, as well as powering any operator-added accessory	S
Installation provisions for customer specific electronic components (fare boxes, cameras, destination signs, passenger counters, etc.)	S

Coach Operation and Performance

Brushless motors on HVAC evaporator and condenser for long life and low maintenance	S
Radiator and charge air cooler with state-of-the-art e-coated frame and high-strength aluminum alloy designed and tested for highly corrosive environments	S
Stainless steel, corrosion resistant coolant and charge air cooler tubes	S
Corrosion resistant condenser with state-of-the-art e-coating on tubes and fins	S
Rotary main battery disconnect switch	S
MCI A/C compressor with improved tensioning system and idler	S
Service door hinges with greaseable fittings	S
Corrosion control enhancements including improved SST rear J-box, more SST bracketry and improved processes for applying HydroArmor in the factory (air tanks, under carriage coverage)	S
Improved docking and cornering light logic for enhanced low-speed visibility and passenger entry / exit	S
Flat composite baggage bay flooring for improved corrosion resistance and driver ease-of-use	S

Support, Services and Warranty

Industry-leading standard 24-month limited warranty including 12-year structural warranty	S
Extended OEM warranties on engine and transmission	O

General Weights and Measurement	D45 CRT LE (Base)
Overall Length (bumper to bumper)	45.58 ft - 13.80 m
Wheelbase	315.00 in - 8.00 m
Front Overhang	78.25 in - 1.99 m
Rear Overhang	150.25 in - 3.82 m
Overall Width	102.00 in - 2.59 m
Overall Height	138.00 in - 3.51 m
Interior Height	78.25 in - 2.14 m
Front Track	84.84 in - 2.15 m

General Weights and Measurement	D45 CRT LE (Base)
Rear Track (drive)	75.38 in - 1.91 m
Rear Track (trailing)	84.84 in - 2.15 m
Turning Radius	40 ft 11 in - 12.42 m
Gross Vehicle Weight	54,000 lb - 24,494 kg
Total Luggage Compartment Volume	135 cu ft w/o parcel rack 220 cu ft w/parcel rack
Fuel Tank Capacity (usable)	183 gal
DEF Tank Capacity	15 gal
Payload Capacity	16,000 lbs

Model variants underway

To better serve operators with commuter express service, MCI will offer a suite of variants based on the Commuter Rapid Transit CRT platform to be released in the coming years. Specifically:

Model	Start of production	Specification
D45 CRT LE	2018	New. 45ft. w/Low-Entry (LE) second door w/ramp.
D45 CRT	2019	45ft. w/wheelchair lift.
D45 CRTe LE	2020	New. 45ft. w/Low-Entry (LE) second door and battery-electric propulsion.
D45 CRT LR	2021	45ft. w/Low Roof, w/ wheelchair lift.
D40 CRT	2022	40ft. w/wheelchair lift.



Leadership in public transit

MCI has been building road-based public transit for decades. We consider the MCI D45 CRT LE a company milestone for its accessibility, comfort and environmental leadership.

Whether your agency's goal is to improve air quality, lower operational costs or expand commuter express service into new areas, the MCI D45 CRT LE, like all predecessor commuter coaches, will prove to be one of the safest, most comfortable, and flexible transportation solutions available.

Reliable service and support

Our new Quality and Customer Service Group aligns MCI's field service, technical call center, warranty operations, service centers and factory quality teams under OEM to better link field and factory. The structure encourages seamless sharing of knowledge between MCI and your agency for maximum uptime.

Customers first

We're Reliability Driven™ for you. MCI's innovations are driven by your requirements, your regulatory demands and your passengers' ever-changing needs. Our lines of communication are always open through executive-level discussions, association annual meetings and our own events, training workshops and field reports. Our sole purpose? To serve our customers with reliable coaches and create a seamless team around every customer need. That's why our newest MCI D 45 CRT LE is a giant leap forward, with high-impact improvements for passengers, drivers and operators. In creating this coach, our design and engineering teams listened to extensive feedback focused on accessibility, riding comfort and curb appeal. The result? A commuter coach with features and benefits far ahead of its time.



★ MCI Sales and Service Centers

Blackwood, New Jersey

14 Harmon Drive
Blackwood, NJ 08012
800-262-1287

Dallas, Texas

9787 Clifford Drive
Dallas, TX 75220
800-248-4942

Des Plaines, Illinois

200 East Oakton Street
Des Plaines, IL 60018
800-428-7626

Los Alamitos, California

10850 Portal Drive
Los Alamitos, CA 90720
800-777-4101

NEW!

San Francisco Bay Area

4120 Point Eden Way
Hayward, CA 94545
800-233-5574

Montreal, Quebec

3500 rue Saint-Patrick
Montreal, QC H4E 1A2
800-663-3328

Winter Garden, Florida

1155 Elboc Way
Winter Garden, FL 34787
800-390-0287

24/7 Emergency Roadside Assistance: 800-241-2947

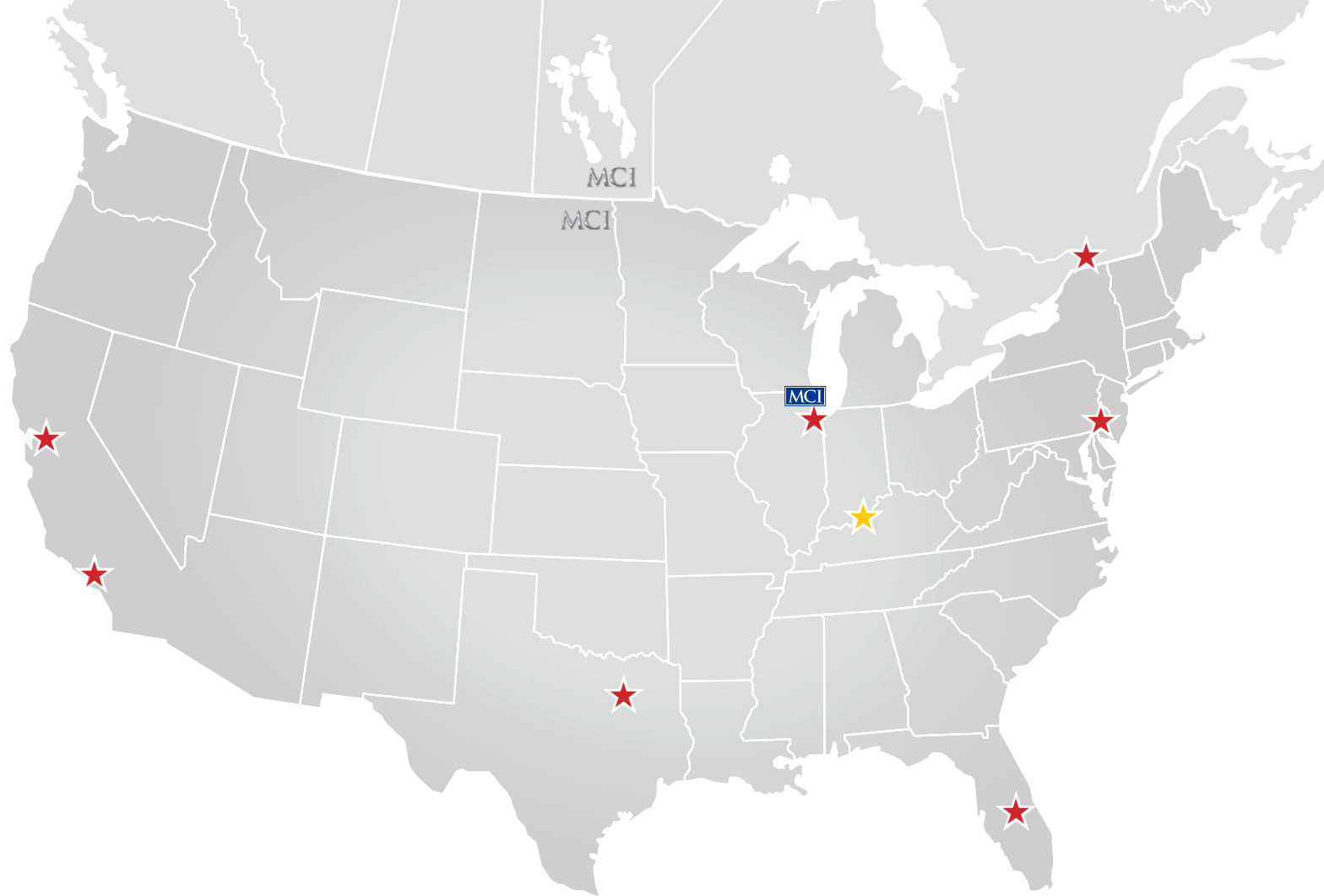

MCI MCI Corporate Headquarters

Des Plaines, Illinois
200 East Oakton Street
Des Plaines, IL 60018
800-428-7626

MCI MCI Manufacturing Facilities

MCI Manufacturing Winnipeg
1475 Clarence Avenue
Winnipeg, MB R3T 1T5

MCI Manufacturing Pembina
552 West Stutsman Avenue
Pembina, ND 58271

★ MCI Parts

7001 Universal Coach Drive.
Louisville, KY 40258
U.S. 800-323-1290
Canada 800-665-0155



Motor Coach Industries | **Phone:** 866-MCICoach | **www.mcicoach.com**